

A

B

C

D

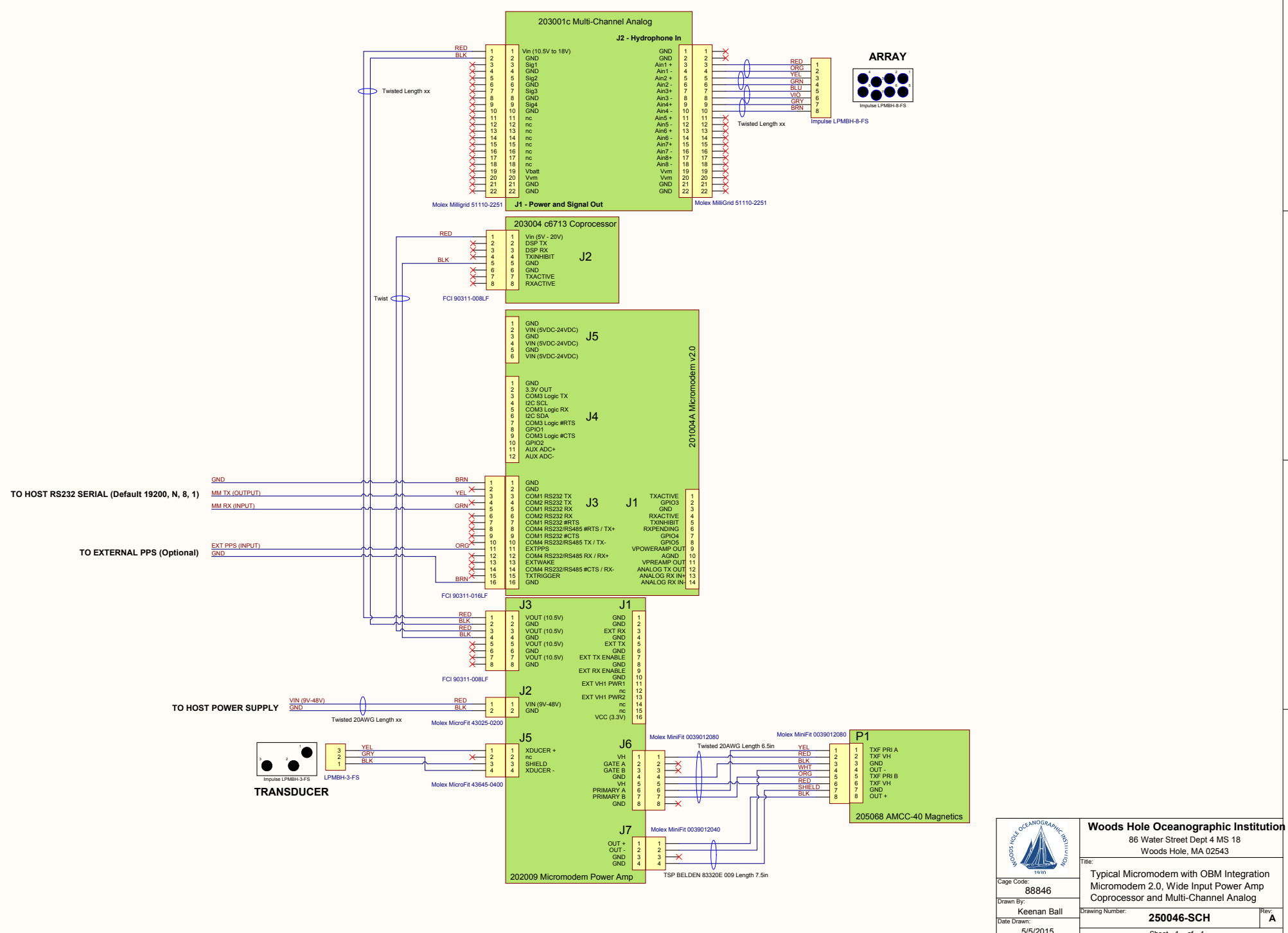

**WOODS HOLE OCEANOGRAPHIC INSTITUTION**  
 86 Water Street Dept 4 MS 18  
 Woods Hole, MA 02543

**Woods Hole Oceanographic Institution**  
 86 Water Street Dept 4 MS 18  
 Woods Hole, MA 02543

Title: **Typical Micromodem with OBM Integration  
 Micromodem 2.0, Wide Input Power Amp  
 Coprocessor and Multi-Channel Analog**

Cage Code: **88846**

Drawn By: **Keenan Ball**

Date Drawn: **5/5/2015**

Drawing Number: **250046-SCH**

Rev: **A**

Sheet 1 of 1