

Model BT-25UF

BTech's Model BT-25UF transducer is an ideal solution for underwater acoustic communication (ACOMMS).

Specifications (Nominal):

- Resonance Frequency (f_r): 25 kHz
- Suggested Range: 17 – 32 kHz
- TVR at f_r : 140 dB re 1 $\mu\text{Pa}/\text{V}$
- OCVS at f_r : -190 dB re 1 $\text{V}/\mu\text{Pa}$
- Horizontal Directivity: Omnidirectional
- Vertical Directivity: Toroidal

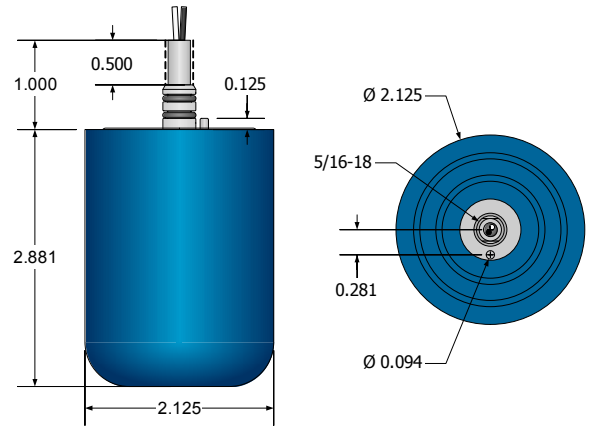

Performance Curves (Nominal):

