

Model BT-2RCL

BTech's Model BT-2RCL transducer is a proven standard for underwater acoustic communication (ACOMMS).

Specifications (Nominal):

- Resonance Frequency (f_r): 28 kHz
- Suggested Range: 20 – 40 kHz
- TVR at f_r : 141 dB re 1 $\mu\text{Pa}/\text{V}$
- OCVS at f_r : -191 dB re 1 $\text{V}/\mu\text{Pa}$
- Horizontal Directivity: Omnidirectional
- Vertical Directivity: Toroidal

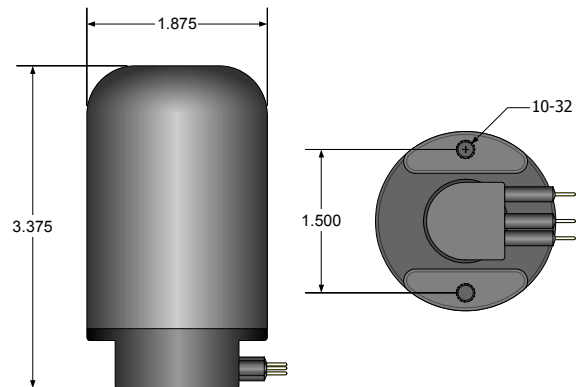

Performance Curves (Nominal):

